

DIMENSIONS:	
A	3.750" ±0.063
B	4.186" ±0.125
C	4.500" ±0.063
D	2.030" ±0.063
E	3.000" ±0.063
F	3.750" ±0.063
G	0.750" ±0.125

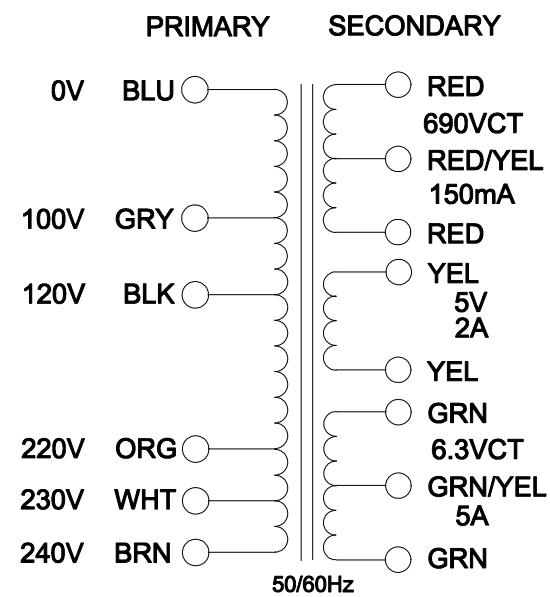
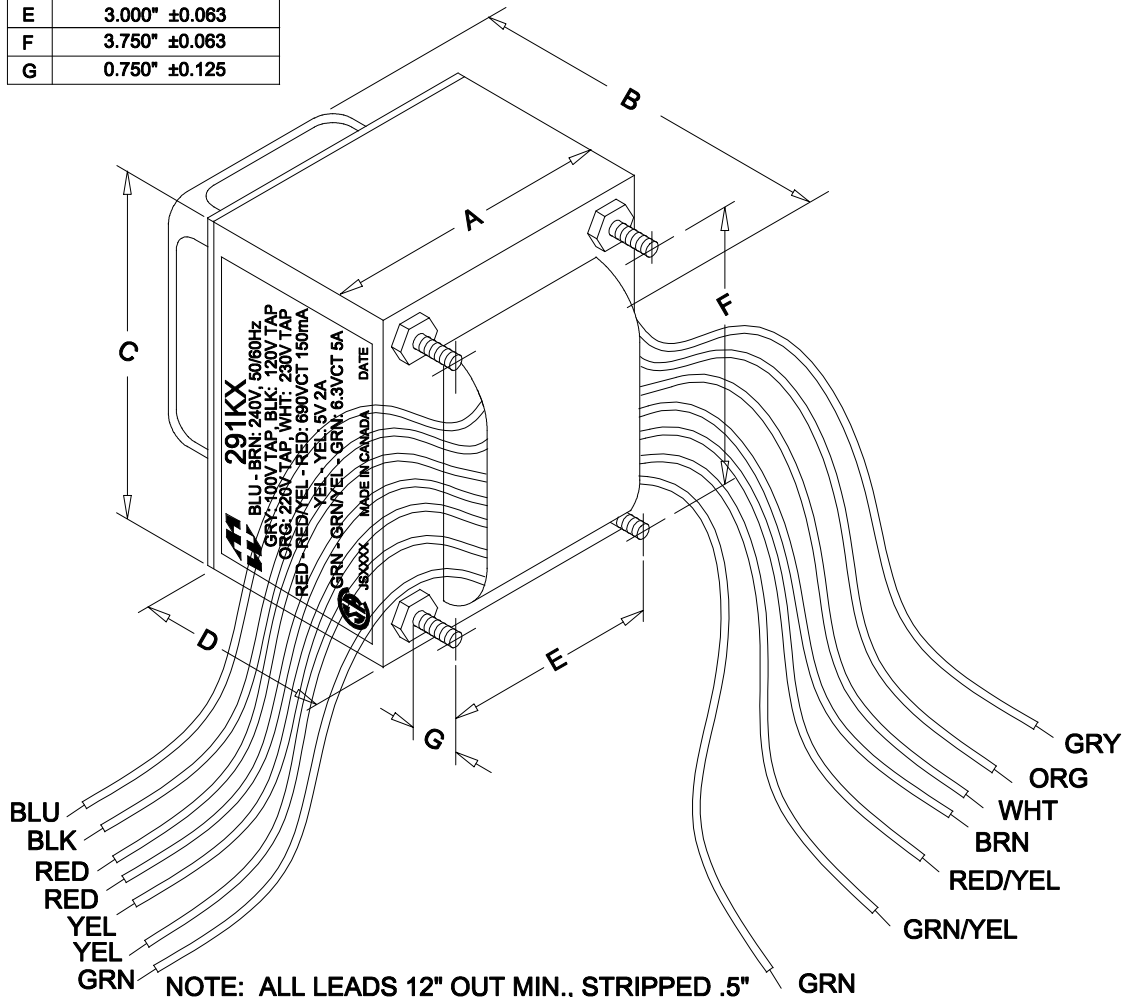

ELECTRICAL DATA:			
TESTS	CONDITIONS	ACCEPTANCE CRITERIA	
Iex	@ 240V, 60Hz, BLU - BRN	210mA	Max.
Sec. N.L.V	@ 240V, 60Hz, BLU - BRN		
	BLU - GRY =	100.1V	±2%
	BLU - BLK =	120.0V	±2%
	BLU - ORG =	220.1V	±2%
	BLU - WHT =	230.3V	±2%
	RED - RED =	707.1V	±2%
	RED - RED/YEL = RED/YEL - RED =	353.5V	±2%
	YEL - YEL =	5.381V	±2%
	GRN - GRN =	6.457V	±2%
	GRN - GRN/YEL = GRN/YEL - GRN =	3.229V	±2%
DCR	@ 20°C, BLU - GRY =	1.262 Ω	±20%
	@ 20°C, BLU - BLK =	1.513 Ω	±20%
	@ 20°C, BLU - ORG =	4.458 Ω	±20%
	@ 20°C, BLU - WHT =	4.666 Ω	±20%
	@ 20°C, BLU - BRN =	4.862 Ω	±20%
	@ 20°C, RED - RED =	51.54 Ω	±20%
	@ 20°C, YEL - YEL =	0.033 Ω	±20%
	@ 20°C, GRN - GRN =	0.016 Ω	±20%
HIPOT	PRIMARY - SECONDARY	3000V, 60Hz, 1 SEC	

REV.#	REVISION	DATE
0	RELEASED. C.I.	11/14/19

**HAMMOND MANUFACTURING** ELECTRONIC DIVISION  
 52 RANKIN PLACE, WATERLOO, ONTARIO, N2J 3Z5  
 PH # (519) 886-6181 FAX # (519) 886-9540

DWG. BY: C. ILIE	CHK'D BY:	TITLE: POWER TRANSFORMER	DWG. NO. 291KX
DATE: 11/14/19	APP'D. BY:		
	DIMENSIONS: IN(X) MM( )		